

Supporto AZ/EL per parabole Ø 120 mm

AZ/EL support for satellite dishes of Ø 120 mm

CE

art. 11-125

SUPP. AZ/EL/76 G

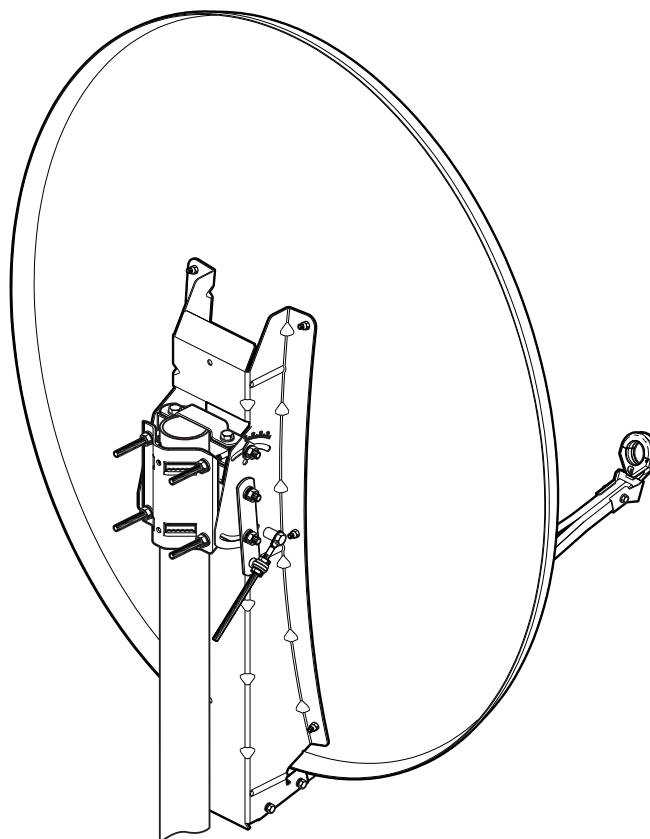

WARNINGS

We strongly encourage you to read this manual before installation and use of the product and strictly observe the recommendation hereof.



Installation shall be carried out by qualified personnel. Mounting instruction has to be carefully observed.



For installation and use, please observe all specific regulation and laws applicable in the destination country.



Carefully read all safety regulations. Failure to observe the indications reported, can cause serious damages to third parties.



If not otherwise indicated, for tightening of screws, bolts and in general threaded rods, refer to applicable figures reported in Tab. 2 in the paragraph General Installation Instructions for GIBERTINI Antennas

NOTES ABOUT DISPOSAL



The barred bin symbol indicates that the product must be disposed of separately from other waste and cannot be thrown into the domestic waste at the end of its life. The user will therefore take the appliance at the end of its life to the suitable separated collection centres for metal parts waste in their own town. An adequate separated collection for sending of the appliance to recycling, treatment and environmentally compatible disposal helps to avoid possible negative effects on the environment and on health thus favouring the reuse and recycle of the materials of which the appliance is made of. The unauthorised disposal of the product by the user causes the application of administrative fees provided for by the regulation in force.



The producer reserve the right to change specifications to products and to documentations without prior notice.

Rev. 0 01.2017



CONTENTS OF THE PACKAGE

CE

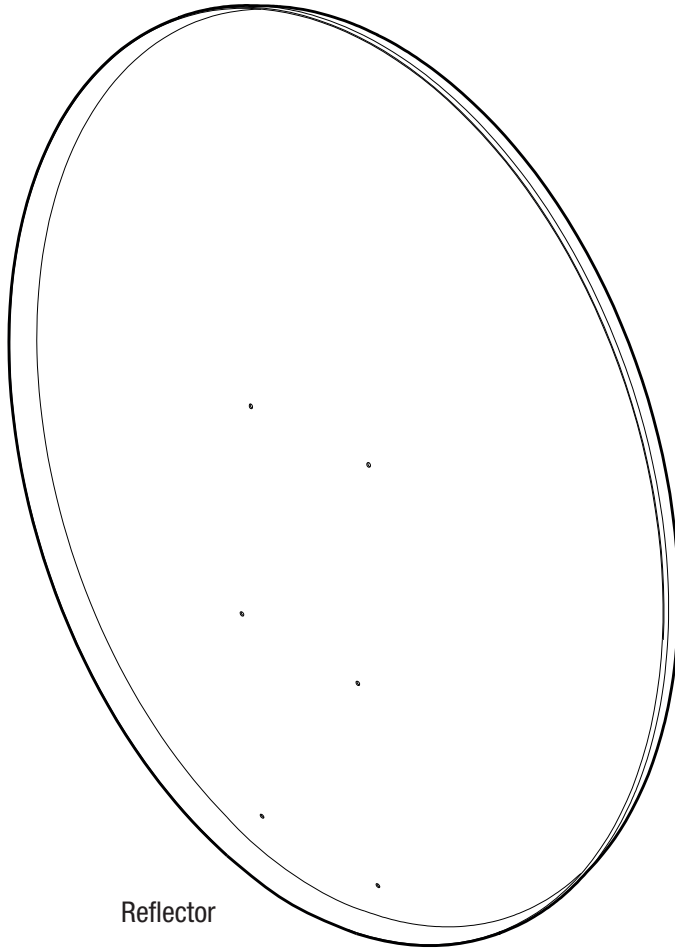

Reflector

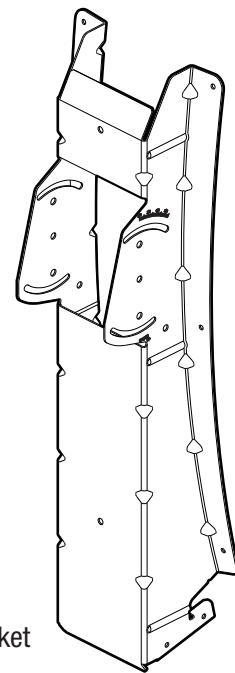

Bracket

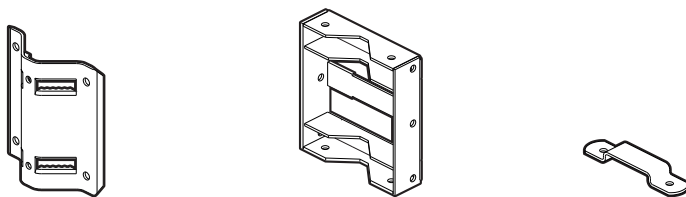

Pole Clamp components

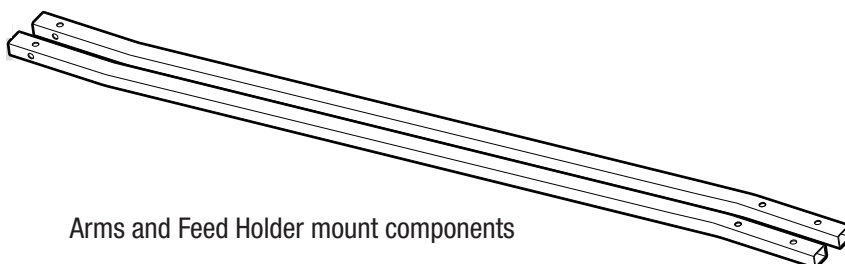

Arms and Feed Holder mount components



CONTENTS OF THE PACKAGE



1 Elements and thread parts for Pole mount unit

 n° 2 M8x20 - ISO 4017 - UNI 5739 - DIN933

 n° 6 M8 - ISO 4033 - UNI 5587

 n° 6 Ø8 - DIN 6798A - UNI8842A

 n° 6 Ø8 - ISO 7089 - UNI 6592 - DIN125A

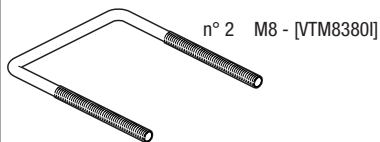

3 Elements and thread parts for Bracket and pole mount unit assembly

 n° 3 M8 - ISO 4033 - UNI 5587

 n° 3 Ø8 - DIN 6798A - UNI8842A

 n° 2 Ø8 - ISO 7089 - UNI 6592 - DIN125A

 n° 1 [VHIPID-G]

 n° 3 M8x170 - ISO 4014 - UNI 5737 - DIN931

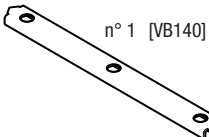
 n° 1 [VB140]

2 Elements and thread parts for Elevation adjuster

 n° 4 M8 - ISO 4033 - UNI 5587

 n° 2 Ø8 - DIN 6798A - UNI8842A

 n° 2 Ø8 - ISO 7089 - UNI 6592 - DIN125A

 n° 1 L=30 - [VP030]

 n° 1 M8x40 - ISO 4017 - UNI 5739

 n° 1 L=20 - [YVD20G]

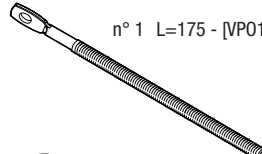
 n° 1 L=175 - [VP0175]

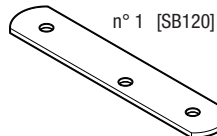
 n° 1 [SB120]

4 Elements and thread parts for Arms and feed holder mount

 n° 5 M6 - ISO 4032 - UNI 5588 - DIN934

 n° 5 Ø6 - DIN 6798A - UNI8842A

 n° 5 Ø6 - ISO 7089 - UNI 6592 - DIN125A

 n° 4 M6x25 - ISO 4017 - UNI 5739 - DIN933

 n° 1 M6x45 - ISO 4017 - UNI 5739 - DIN933

5 Elements and thread parts for Antenna reflector

 n° 6 M6 - ISO 10511 - DIN 985 - UNI7474

 n° 6 [VTC612]



ASSEMBLING STEPS

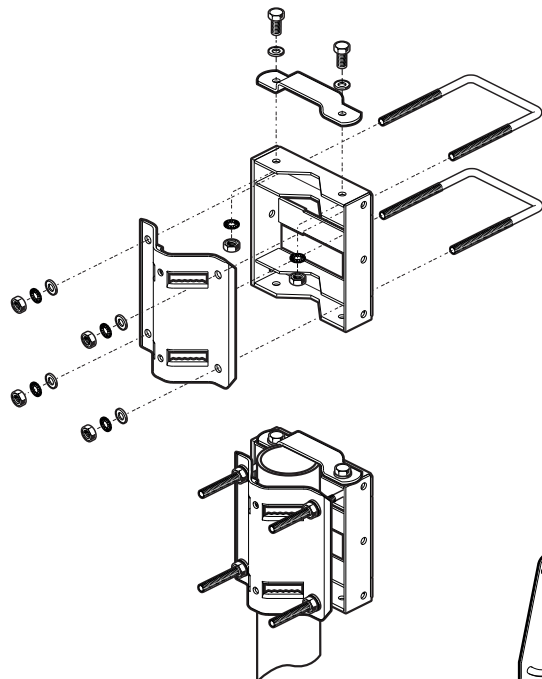

① Assembly of the pole clamp unit



A fixing pole with a diameter from 75mm up to 90mm and thickness of 3mm is highly recommended.

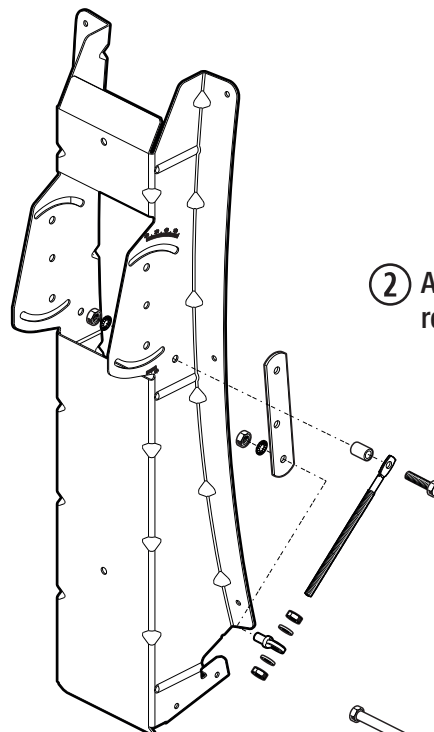

② Assembly of the Elevation fine regulation threaded tie-rod

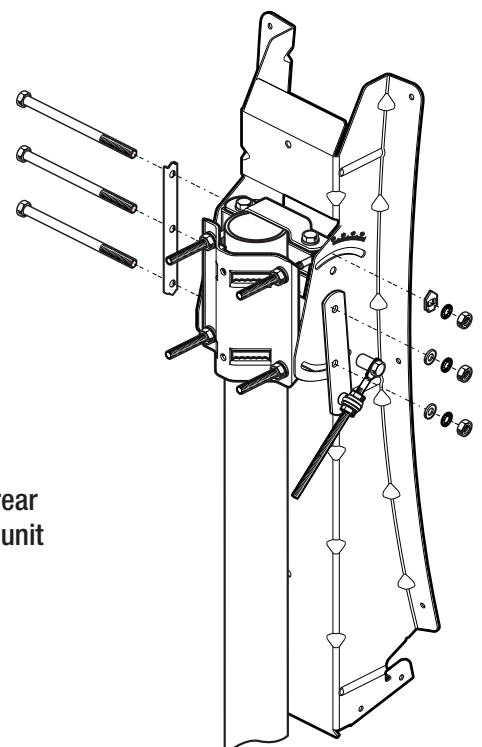

③ Assembly of the antenna rear bracket to the pole clamp unit



ASSEMBLING STEPS

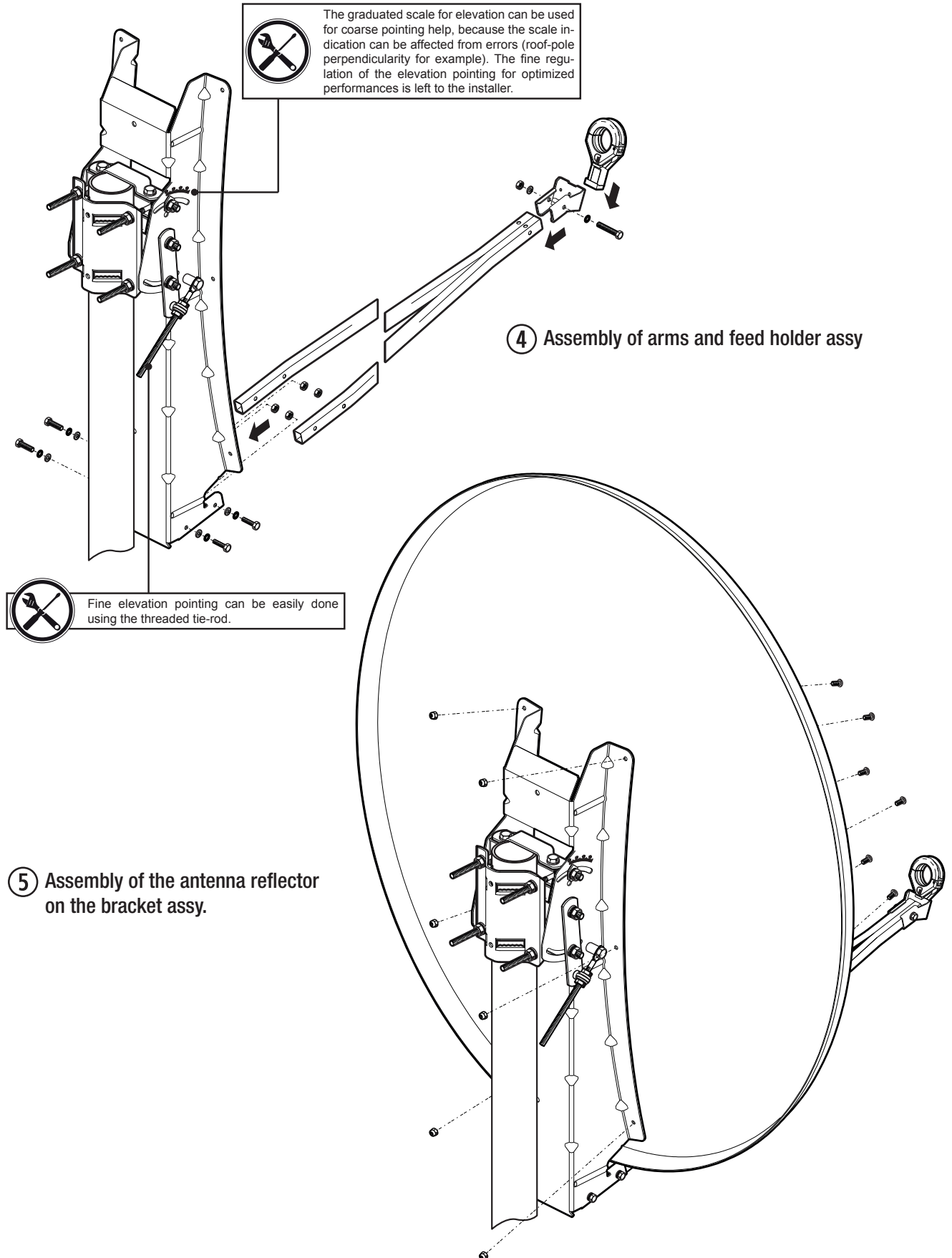

Installation

All the dishes are manufactured using well certified materials and assembly components that ensure a reliable and long life product.

During installation, for proper use and safety, screws and bolts have to be used in proper indicated place without exchange in position (e.g. do not use a M4 bolt where an M6 is foreseen).



The personnel in charge of installation will be the sole responsible of the pole fixation on roof or wall, and have to take care of the proper tightening between antenna components. If not elsewhere indicated, the following table report the recommended tightening torque, in Newton * meter, to be applied on different mechanical couplings.

Thread size	Tightening Torque Bolt/Nut assembly		Tightening Torque Bolt/Insert assembly	
	min [Nm]	max [Nm]	min [Nm]	max [Nm]
pitch				
M3	1.1	1.5	0.7	1.1
M4	2.2	3.1	1.5	2.2
M5	4.2	6.0	2.9	4.2
M6	7.3	10.4	5.1	7.3
M8	17.1	24.4	12.0	17.1
M10	35.1	50.1	24.5	35.1

Maintenance Plan

All the dishes have shown good durability even in worst conditions, provided than no permanent damages to plating or painting have been procured during the installation or due to other origins after installation.

Nevertheless, a periodic maintenance enforce the warranty validity and help in order to elongate the life of the assembly.

Period	Every two years or in case of storm wind and/or strong hailstorm
General care	Verify the integrity of the antenna assembly. Clean with a conventional duster the dish surface and the LNB feed -do not use solvents for normal cleaning- dry cleaning is normally enough, use water or alcohol to remove solid attached elements, dry with a cloth.
Paint	If the painting has been ruined, remove gently the rust, if present, using a fine abrasive paper (type 00), then clean with acetone, chloroform or similar oil free solvent, dry and than repaint with two pass of -water based- opaque paint of the proper RAL. (Conventional paint used in car repair. Please refer to the paint Manufacturer recommendations for the latency time between the painting).  Chemical solvents are flammable and volatile : do not expose directly, protect with mask and gloves. Use only opaque paints. Brilliant paints can over heat the LNB "cooking" it with permanent damages.
Zinc plating	If damaged due to environmental corrosion, zinc plating can be restored with a chemical zinc spray (ZINK TK0105 by TECNICA -Italy- or similar products from other Manufacturers like TALKEN, etc.). Using a metallic brush remove oxidation and rust if present, clean with acetone, chloroform or similar oil free solvent and live it to dry. Apply one or two pass of spray zinc, having care to cover uniformly all the exposed surfaces (this apply specifically the clamp brackets). Carefully follow the indications of the spray zinc Manufacturer.  The spray contain Toluene: flammable, do not expose to fire, do not smoke, do not dry with direct flame or hot air irons at temperature higher than 80°C. Vapors can cause irritation and narcotic effects, protect with mask and gloves.

